

**FC8** **STREACOM**  
**USER GUIDE**

## Page

2.....	Index, Foreword
3.....	Product Overview
4.....	Preparation for Assembly
5 - 6 .....	Installing the Motherboard
7.....	Installing the Passive CPU Cooler
8.....	Fitting the HDD/ODD
9.....	PCB Wiring Diagram
10.....	Installing the PCI Card and Top Panel

## Foreword

Thank you for your purchase of this Streacom product. Every care has been taken to ensure that it meets with the highest quality and standards that we have set for ourselves.

Should you have any questions that are not covered in this user guide, support can be offered via email through our website at [www.streacom.com](http://www.streacom.com)

We sincerely hope that you enjoy using our product!

## Specification

Chassis Material	Aluminum
Available Colours	Silver / Black - Brushed Finish
Motherboard Compatibility	Mini ITX
HDD Drive Support	1 x 3.5" + 1 x 2.5"
ODD Drive Support	Slot loading drive, left side eject button
Cooling Method	Passive - Heat Pipe (65W Max TDH Recommended)
Front Ports	2 x USB, 1 x SD Card Reader
Expansion Slot	1 x Low-Profile Expansion Card
Dimensions	240 x 250 x 100mm (WxDxH)
Power Supply Support	Optional NanoPSU DC power
IR Solution	Optional MCE Compatible IR Receiver & Remote
Net Weight	2.6KG

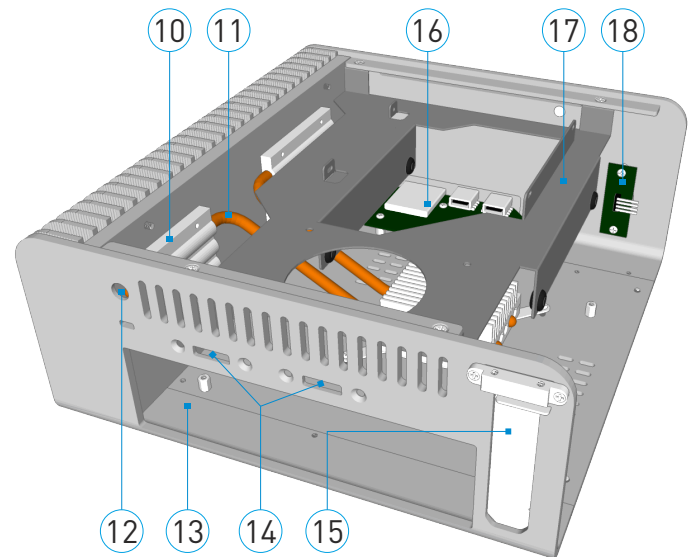
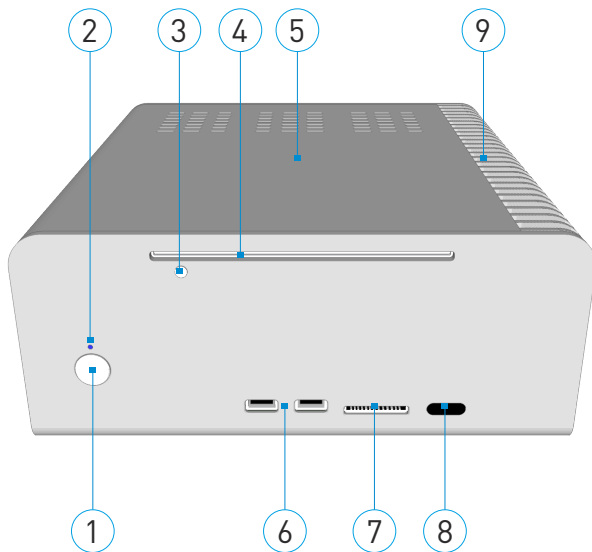

## Key Features

1..... Power Button	7..... SD Card Reader	13.... IO Shield Opening
2..... Power LED	8..... IR Receiver Window	14.... eSata Slots (Optional)
3..... ODD Eject Button	9..... Heat Sink	15.... PCI Slot (Half-Height)
4..... ODD Loading Slot	10.... Heatsink Connector	16.... USB/SD Card PCB
5..... Top Panel	11.... CPU Cooler Heatpipe	17.... HDD/ODD Cage
6..... USB Ports	12.... DC Power Jack Hole	18.... Power Button PCB

## Removing the Top Panel

The top panel is held in place with 4 screws, 2 at the bottom and 2 at the side. The side screws are accessed between the gaps of the heatsink fins. Remove the screws and slide the top panel away from the chassis

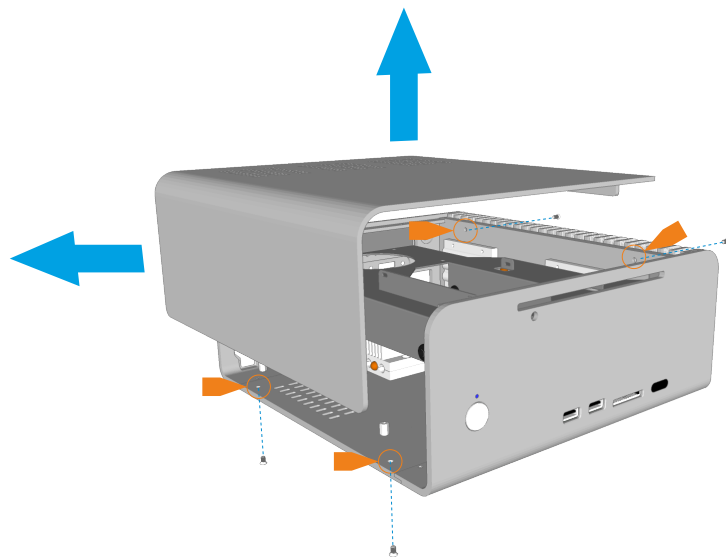
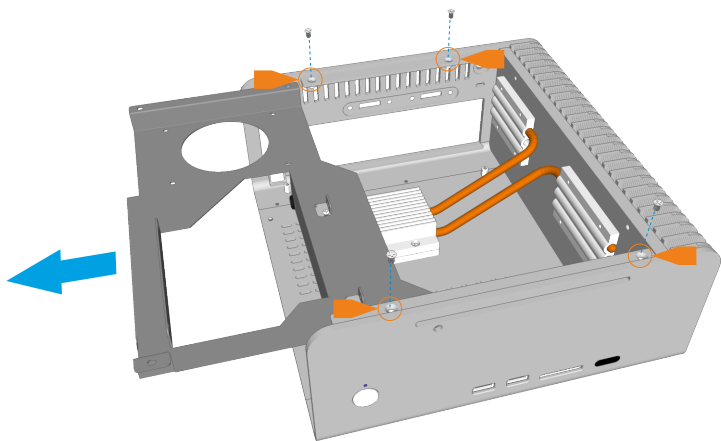

## Removing the HDD/ODD Cage

The HDD/ODD cage is held in place by 4 screws which are all accessible from the top as shown. Once all 4 screws are removed, slide the cage out of the chassis.

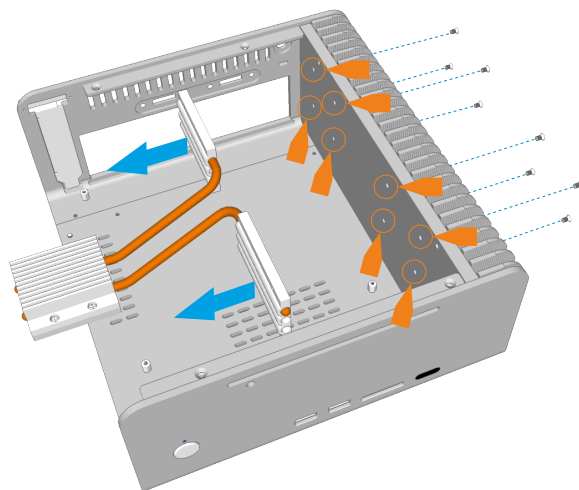

## Removing the CPU Cooler

The heat pipes are connected to the chassis using 2 connector blocks which are held in place with a total of 8 screws (4 for each block). Unscrew all 8 screws which are accessible via the gaps in between the heatsink fins.

## Installing the I/O Shield

Locate the I/O shield that is supplied with your motherboard and firmly push it in place. Ensure that it clicks in place fully otherwise the motherboard will be difficult to fit.

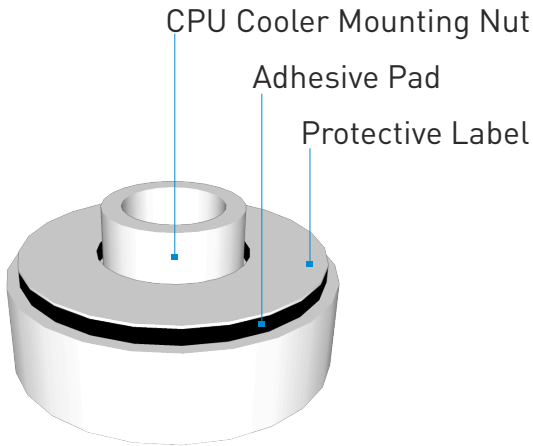
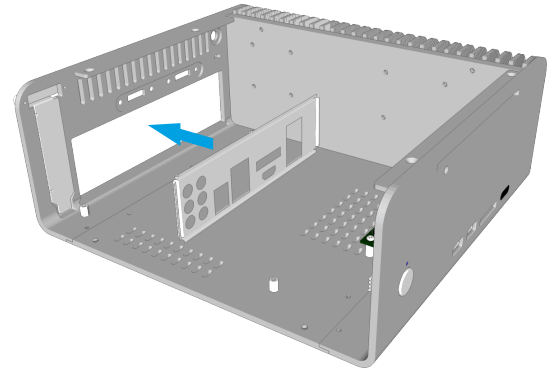

## Fit the CPU Cooler Mounting Nuts

The chassis is supplied with 4 mounting nuts which should be fixed to the motherboard prior to fitting it. The nuts should be fixed to the underside of the motherboard and are held in place by adhesive pads.

With the motherboard upside down, located the 4 CPU cooler mounting holes. Peel the protective label off the mounting nuts and stick them to the underside of the motherboard ensuring they correctly align with the holes.

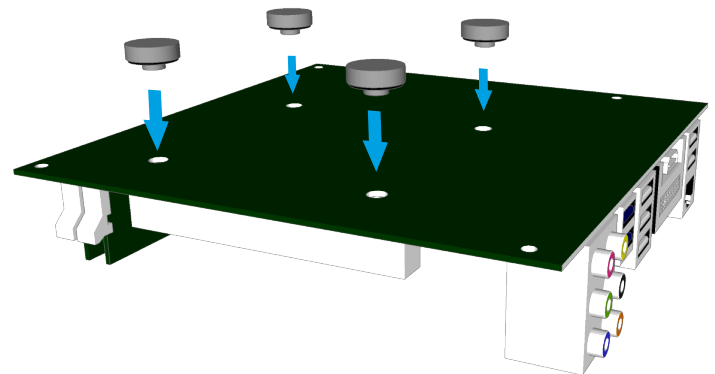

## Installing the Motherboard

Carefully lower the motherboard into the chassis, with the I/O port side leading so that the ports can fit into the I/O shield.

When the motherboard is correctly in position, fix it to the chassis stand-offs using the screws provided. Ensure that all the holes correctly align before fully tightening the screws.

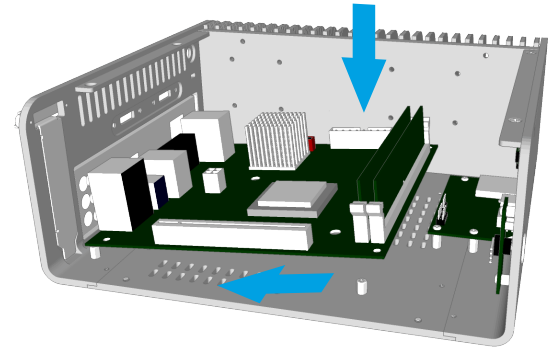

## Connect NanoPSU & Other Cables

With the motherboard in place, you can now connect the PSU and any other internal connectors such as the power button switch. You should also connect the SATA cables in preparation for installing the HDD/ODD cage assembly.

The front USB & card reader require 3 motherboard USB ports, 1 for the card reader, and 2 for the USB ports.

See page 9 for more details.

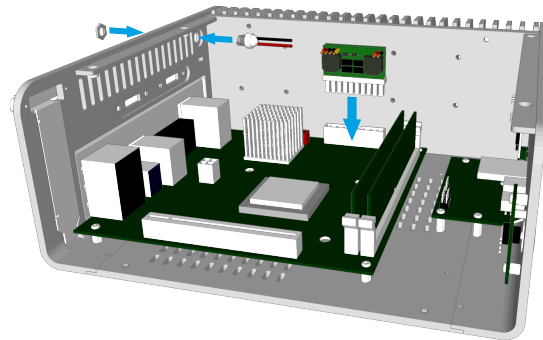

## CPU Cooler Overview

The passive CPU cooler comprises of 3 main parts. The CPU cooler which fixes to the CPU, the heat pipes that transfer the heat, and the heatsink connector blocks that fix the heatpipes to the chassis side panel (heatsink). In order to ensure efficient heat transfer, thermal paste should be applied to the surfaces shown. Do not apply the thermal paste until the parts are ready to be installed.

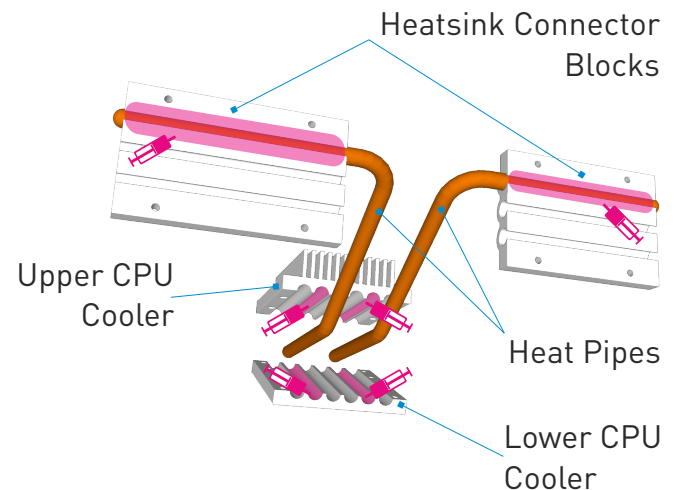

## Attach the CPU Cooler Retention Arms

The kit will include 2 retention arms which should be fixed to the underside of the lower CPU connector. These arms will allow the cooler to be fixed to the CPU and Motherboard. Thermal paste should be applied to the surface that will be in contact with the CPU. The arms are held in place by 4 screws.

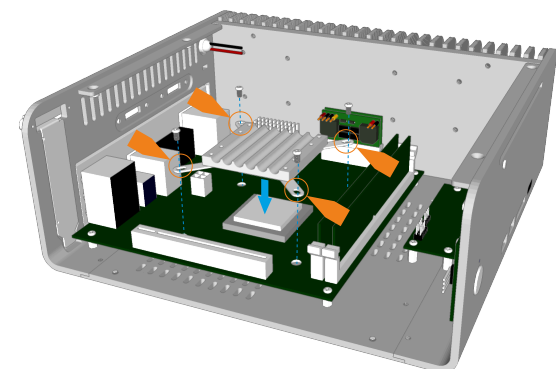
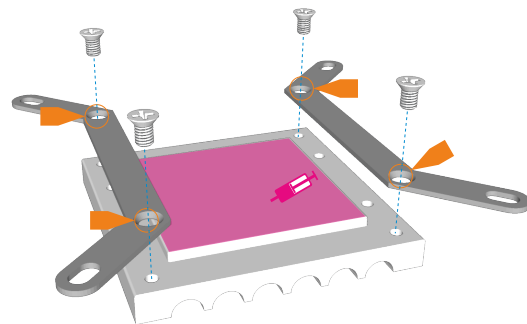

Place the lower CPU cooler onto the CPU ensuring the holes of the mounting arms align with the 4 mounting nuts that were previously fixed to the motherboard. Install all 4 screws and gradually tighten each one so that equal pressure is applied to each corner until all 4 are fully secured.

With the lower CPU Cooler now fixed in place, ensure that thermal paste is applied to all the specified areas and fit the upper CPU cooler, heatpipes and heatsink connector blocks in place. The upper CPU cooler is held in place by 4 screws and the heatsink connectors are held in place by a total of 8 screws, 4 for each side. The heatpipes, connectors and cooler are designed to have an adjustable position which allows for different motherboard CPU locations.

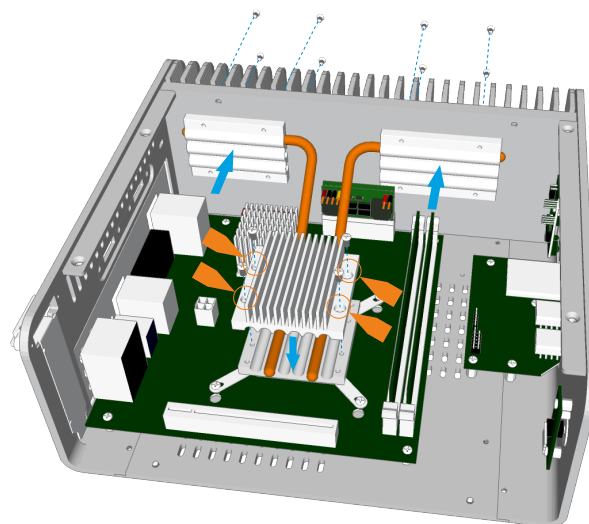

## Installing the HD and OD Drives

With the cage out of the chassis, all the drives can be fitted with ease.

The slot loading optical drive is mounted using 4 screws, 2 either side. The mounting holes are rectangular which allows for small adjustments to the position on the drive. This is useful when adjusting the proximity to the chassis eject button.

The 3.5" hard drive fits under the optical drive and has 4 rubber dampeners to reduce noise from hard drive vibrations.

The 2.5" hard drive can be mounted behind the optical drive and is secured underneath with 4 screws.

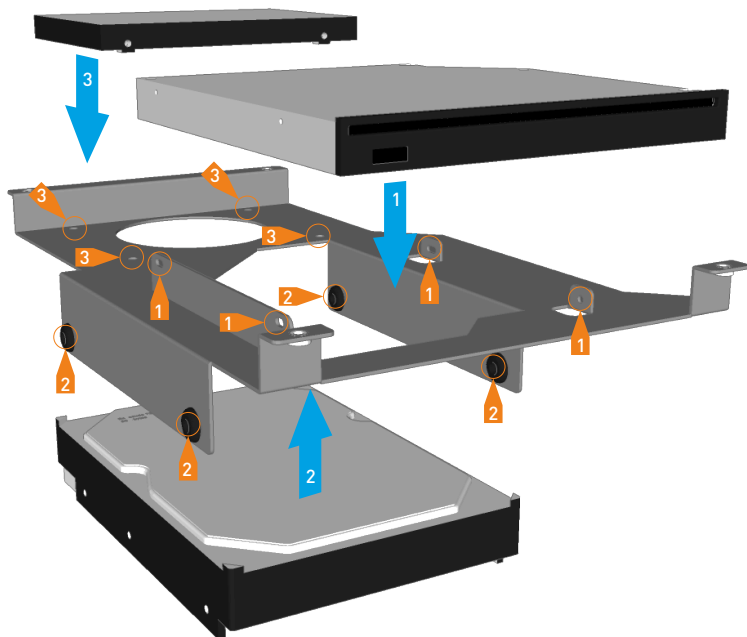

## Fitting the Eject Button and HDD/ODD Cage

Prior to replacing the HDD/ODD cage into the chassis, the ODD eject button should be fitted. The eject button is packed with the other screws and accessories and simply fits as shown into the hole below the ODD slot.

The cage can now be replaced into the chassis. Carefully slide the assembly ensuring cables are routed correctly and that the ODD eject button aligns and is held in place by the optical drive. The cage is secured by 4 screws from above.

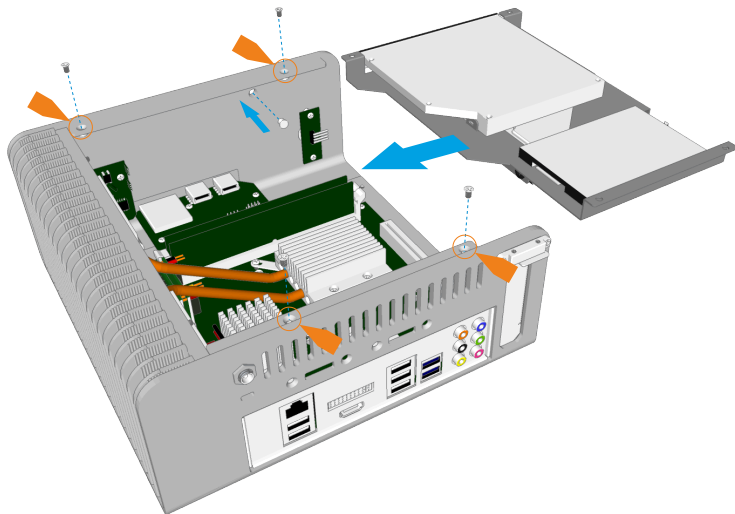

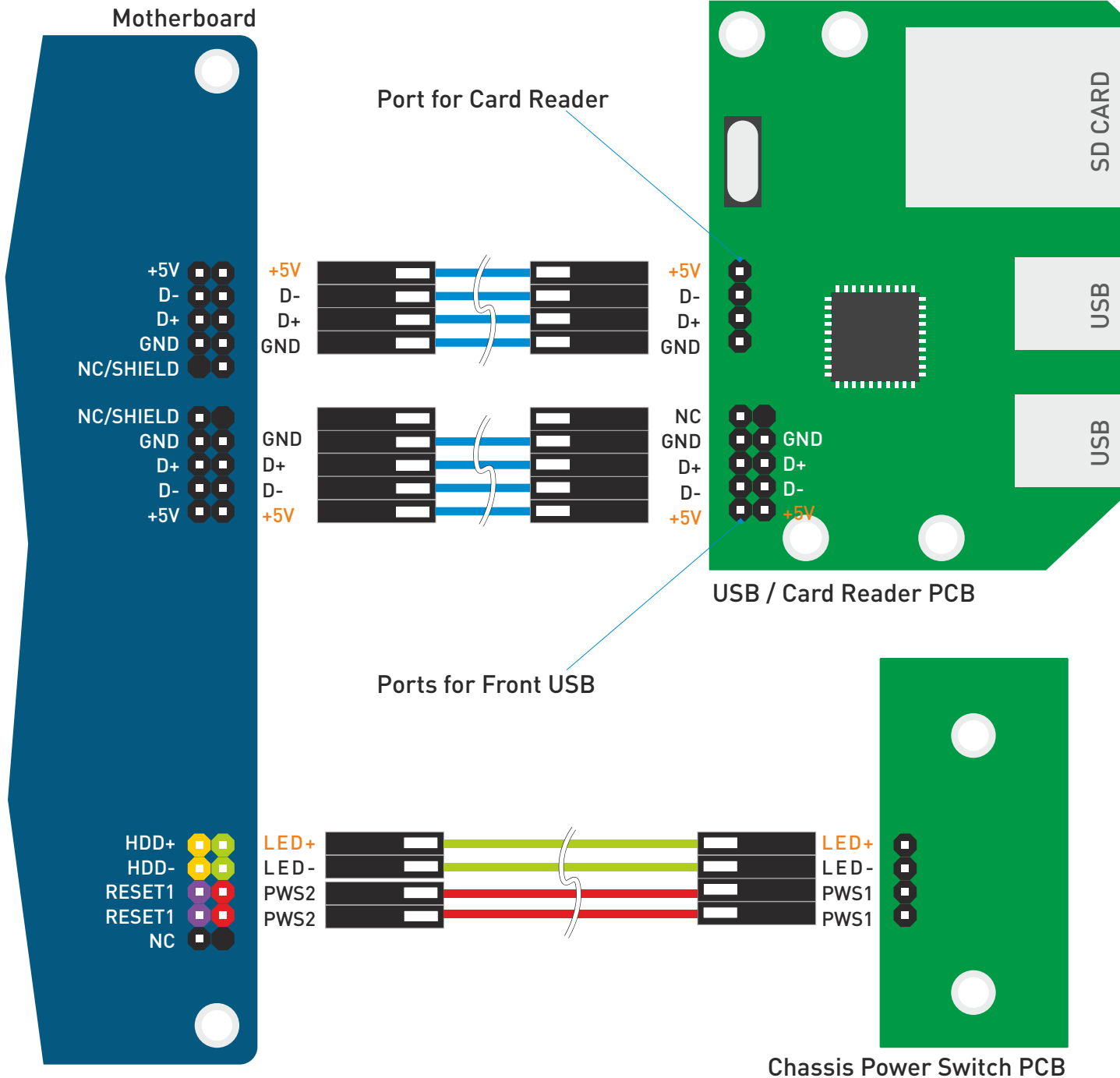

Cable colours shown are for illustrative purposes only, actual colours will vary.

## Installing PCI Card (Optional)

To install an expansion card, first remove the pre-installed PCI blanking plate by removing the single lower screw. The PCI mount can also be removed to make it easier to install the expansion card. This is done by removing the 2 screws either side on the mount.

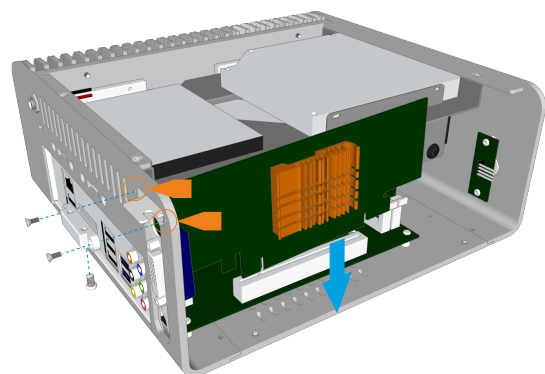
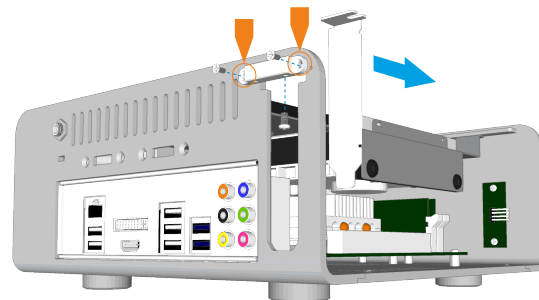

Carefully place the card into the motherboard slot ensuring the rear side (where the ports are located) firstly passes through the expansion slot opening of the chassis. Once the card is fully seated into the motherboard, replace the PCI mount and finally secure the card with the single screw from underneath the mount.

## Replace the Top Panel

With all the components installed, all that remains is to replace the top panel. Prior to doing this, ensure that all cables are connected and all components are securely fitted. Replace the top panel and secure it in place using 4 screws, 2 from the side and 2 from underneath the chassis.

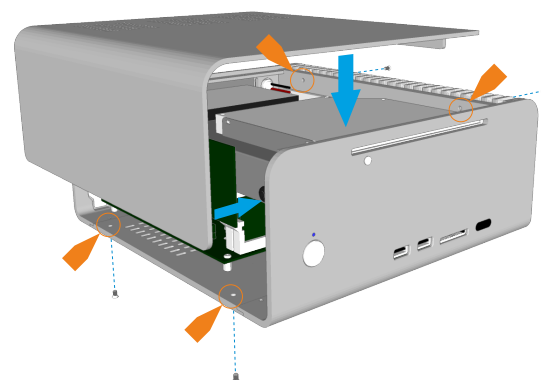

*STREACOM*

Melbournestraat 56,  
3047 BJ Rotterdam,  
The Netherlands  
[www.streacom.com](http://www.streacom.com)

V1.12.02